

Ferrite ring cores (toroids)

TN9/6/3

RING CORES (TOROIDS)

Effective core parameters

SYMBOL	PARAMETER	VALUE	UNIT
$\Sigma(I/A)$	core factor (C1)	5.17	mm ⁻¹
V_e	effective volume	102	mm ³
l_e	effective length	22.9	mm
A_e	effective area	4.44	mm ²
m	mass of core	≈0.5	g

Coating

The cores are coated with polyamide 11 (PA11), flame retardant in accordance with "UL 94V-0".

Isolation voltage

DC isolation voltage: 1 000 V.

Contacts are applied on the edge of the ring core, which is also the critical point for the winding operation.

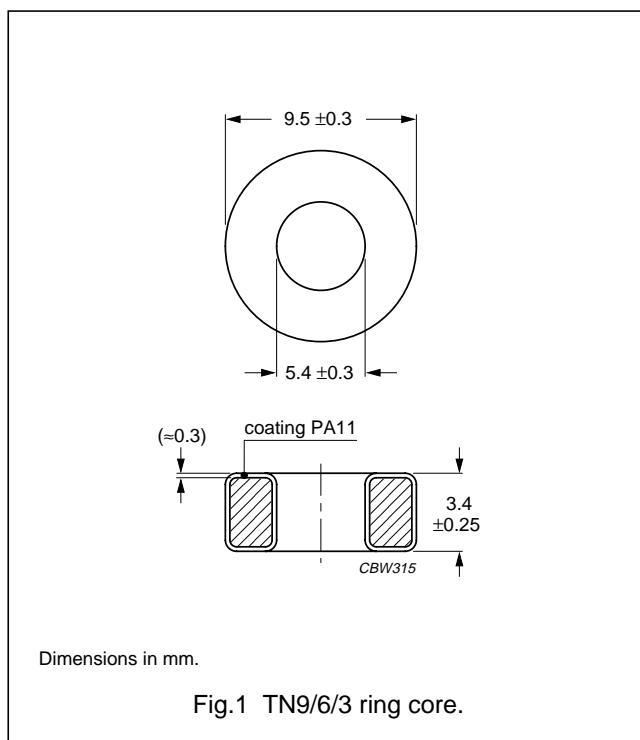

Ring core data

GRADE	A_L (nH)	μ_i	COLOUR CODE	TYPE NUMBER
4C65	30 ±25%	≈125	violet	TN9/6/3-4C65
4A11 ^{sup}	170 ±25%	≈700	pink	TN9/6/3-4A11
3R1 ^{sup}	–	≈800	black	TN9/6/3-3R1 ⁽¹⁾
3F3	440 ±25%	≈1800	blue	TN9/6/3-3F3
3C85 ^{sup}	485 ±25%	≈2000	red	TN9/6/3-3C85
3E25	1340 ±30%	≈5500	orange	TN9/6/3-3E25
3E5	2070 ±30%	≈8500	yellow/white	TL9/6/3-3E5 ⁽²⁾
3E6 ^{des}	2435 ±30%	≈10000	–	TC9/6/3-3E6 ⁽³⁾

Notes

- Due to the rectangular BH-loop of grade 3R1, inductance values strongly depend on the magnetic state of the ring core and measuring conditions. Therefore no A_L value is specified. For the application in magnetic amplifiers A_L is not a critical parameter.
- Ring cores in grade 3E5 are lacquered (polyurethane) and have different dimensions:
Outside diameter = 9.3 ±0.4 mm; inside diameter = 5.75 ±0.3 mm; height = 3.25 ±0.3 mm.
- Ring cores in grade 3E6 are coated with parylene C and have different dimensions:
Outside diameter = 9.0 ±0.2 mm; inside diameter = 6.0 ±0.2 mm; height = 3.0 ±0.15 mm.

WARNING

Do not use grade 3R1 cores close to their mechanical resonant frequency. For more information refer to "3R1" material specification in this data handbook.

Ferrite ring cores (toroids)

TN9/6/3

Tag plate

General data

PARAMETER	SPECIFICATION
Tag plate material	liquid crystal polymer (LCP), glass reinforced, flame retardant in accordance with "UL 94V-0"; UL file number E83005 (M)
Solder pad material	copper-tin alloy (CuSn), tin-lead alloy (SnPb) plated
Maximum operating temperature	155 °C, "IEC 85" class F
Resistance to soldering heat	"IEC 68-2-20", Part 2, Test Tb, method 1B: 350 °C, 3.5 s
Solderability	"IEC 68-2-20", Part 2, Test Ta, method 1: 235 °C, 2 s

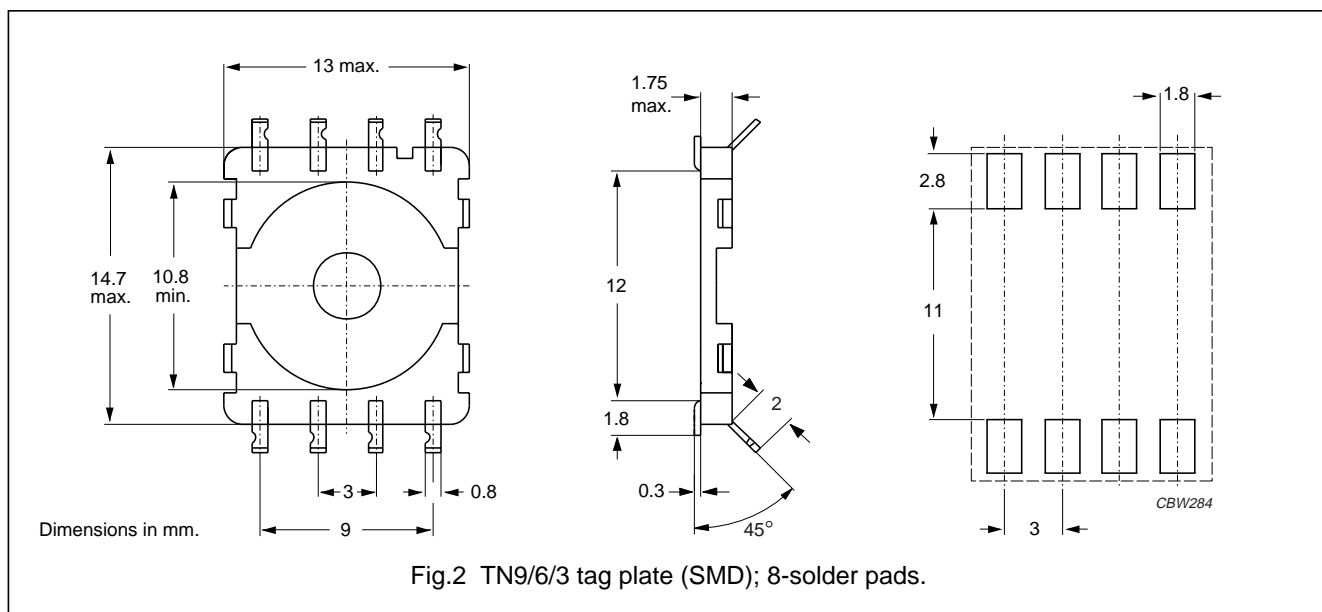

Type number information for TN9/6/3 tag plate (SMD) with 8 solder pads

NUMBER OF SOLDER PADS	TYPE NUMBER
8	TGPS9

Cover data

PARAMETER	SPECIFICATION
Cover material	polyamide (PA4.6) glass reinforced, flame retardant in accordance with "UL 94V-0"
Maximum operating temperature	130 °C, "IEC 85" class B
Type number	COV9

